

DR Model 20

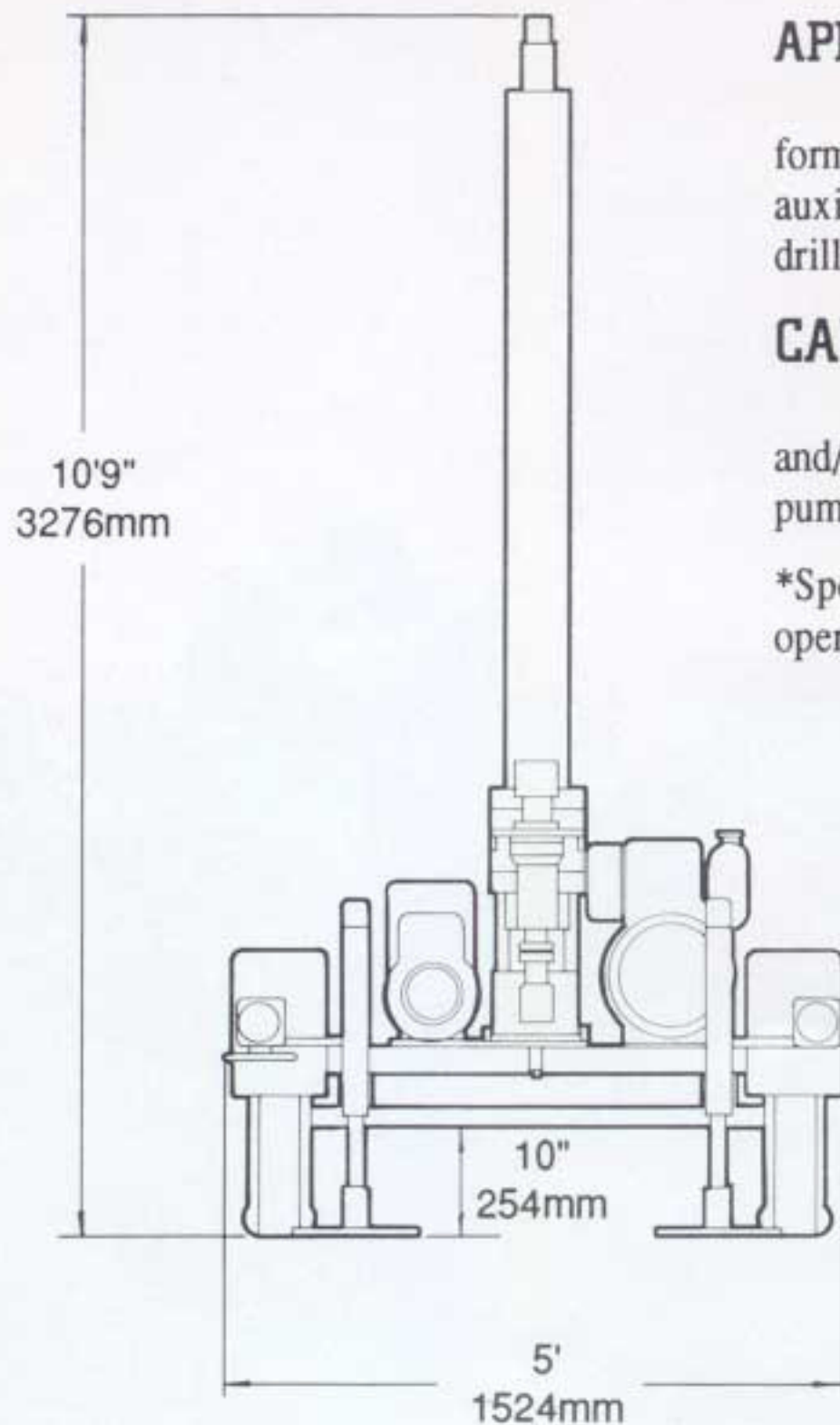

APPLICATIONS:

The DR 20 and DR 20-2 are designed for small diameter shallow holes in unconsolidated formations using the rotary mud method. Rotary air drilling can be accomplished utilizing an auxiliary air compressor. The DR 20 and DR 20-2 are designed for fast drilling, utilizing lightweight drill stem and the DeepRock wrenchless automatic breakout system.

CAPABILITIES:

2" and 4" wells to 200'. Larger diameter wells to shallower depths. For the larger diameter and/or deeper (200') wells, the DR 20-2, utilizing the larger mud pump, is recommended. The larger pump results in faster drilling with quicker hole cleaning capabilities.

*Speed of drilling, diameters and depths obtainable will vary with soil conditions, tooling used and operator proficiency.

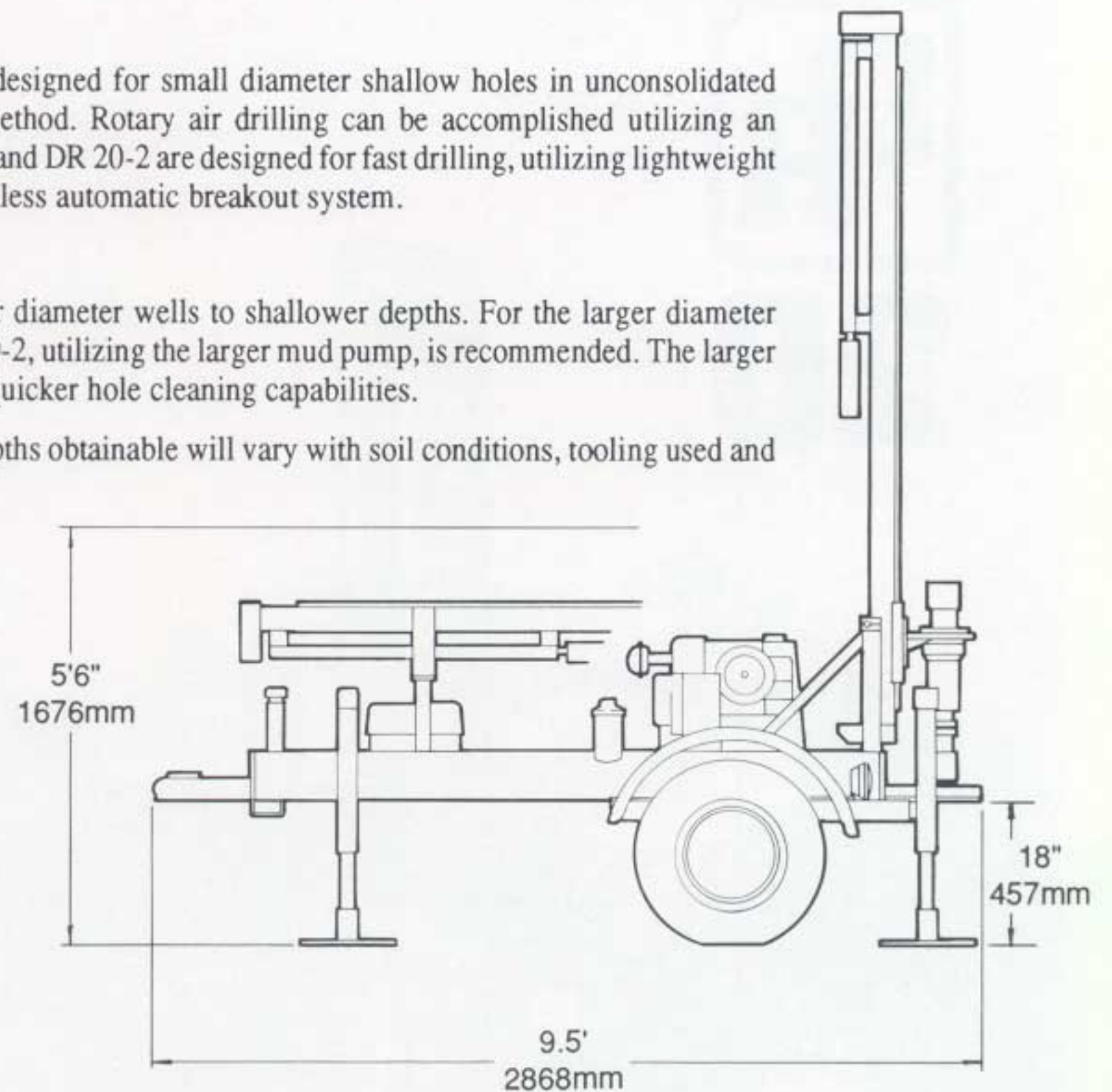

STANDARD EQUIPMENT:

CARRIER:

Single Axle Trailer 2500# Axle 3500# Axle Diesel
Drill Rig, Hydraulic Tank and Axle are unitized
MIG Welded Structural Tubing

POWER:

13 HP Gas engine powers all hydraulics, recoil start
4.5 HP Gas engine powers 2X2 Mud Pump, recoil start

LEVELING JACKS:

3 Manual Screw Type

MAST:

Structural Steel with Skid Plate
Hydraulic Cylinder raises and lowers mast
Tophead Stroke - 76 inches

TOPHEAD DRIVE:

Single Speed Hydraulic motor
Rotation Speed - 115 RPM
Torque - 5000 lb. in. - 13 HP Gas
** Torque - 6500 lb. in. - 14 HP Diesel
Side feed swivel, Direct Drive, Double Bearing
1 1/4" Fluid Passage
Wrenchless Breakout with J-Latch, Saver Sub, Bowl and Slips

PULLDOWN/PULLBACK:

Hydraulic Cylinder
Pulldown - 2200 lbs. - Gas Engine
Pullback - 3500 lbs. - Gas Engine
**Pulldown - 2800 lbs. - 14 HP Diesel Engine
**Pullback - 4400 lbs. - 14 HP Diesel Engine

CONTROL CONSOLE:

Located at right rear of drill
Operator friendly, simple controls
Hydraulic and Engine Gauges

DIMENSIONS AND WEIGHTS - STANDARD UNIT:

Height - Towing Position - 5.5'
Height - Drilling Position - 10.9'
Width - 5'
Length - 9.5'
Weight - 1100 to 1400 lbs.

OPTIONS:

Electric Start for 13 HP Gas Engine
1 1/2 x 2 x 8 1/2 Mud Pump
14 HP Air Cooled Diesel(s)
Mast Extension with Winch
Swing Away Head
Night Drilling Illumination
5', 1.9" Diameter Drill Stem with 4130CA-21 Tool Joints (16lbs.)
Additional Tooling and Bits

Authorized Distributor

*Specifications are for basic models. Customized drill rigs vary depending on options. Our continuing effort to improve this equipment may result in specification changes without notification.



2129 South V W Goodwin Blvd
Marquez, Texas 77865
(855)457-4469
www.DeepRock.com