

DR 100

Specifications

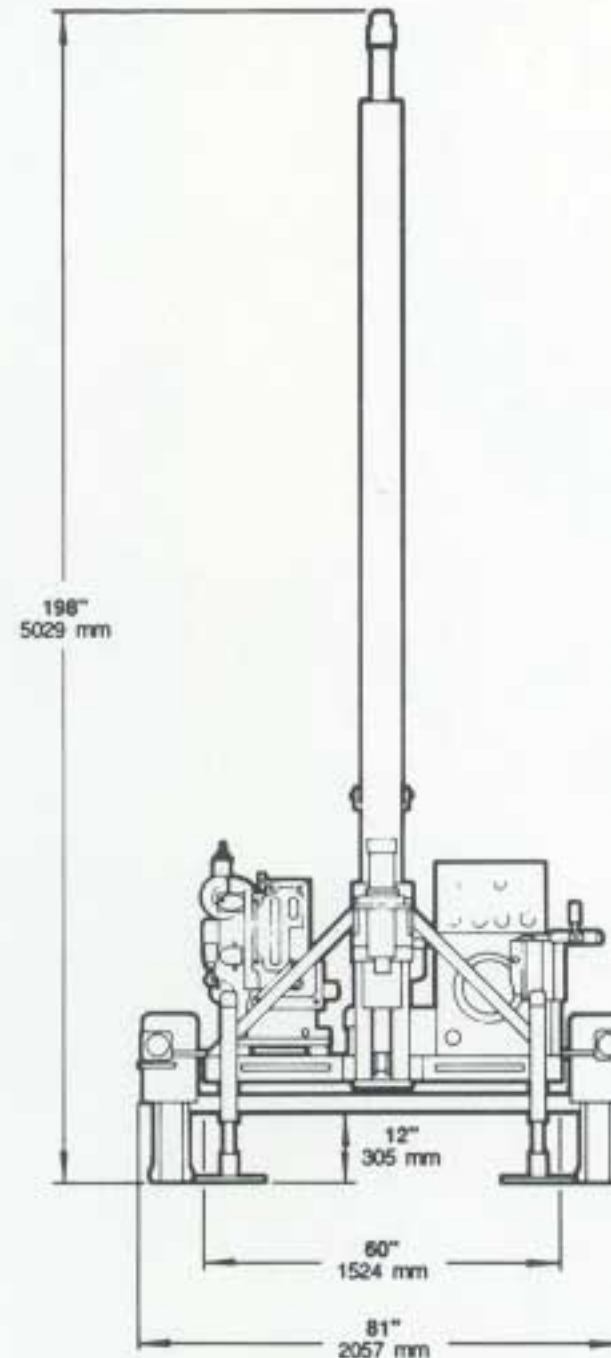
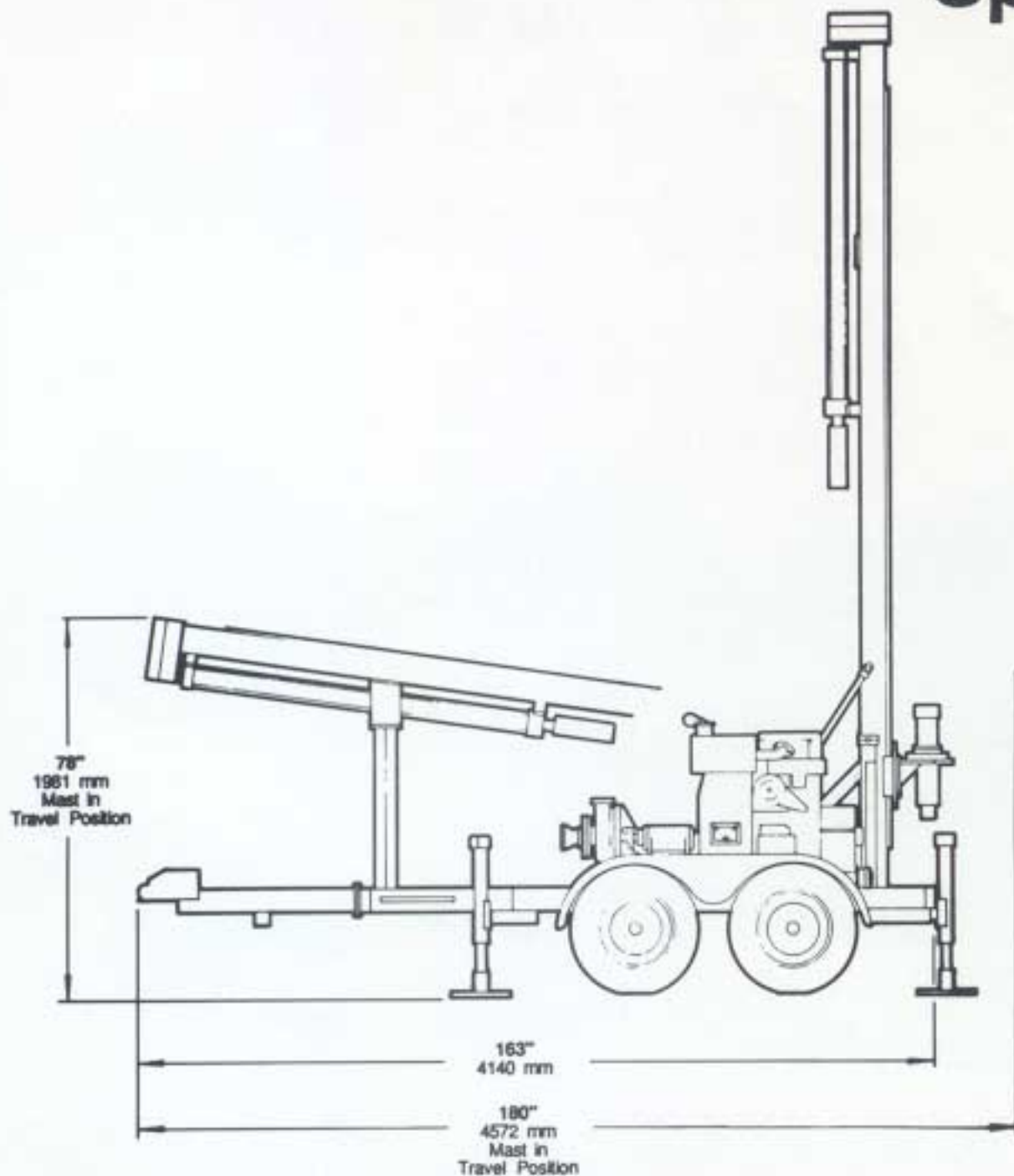

STANDARD EQUIPMENT

• Carrier-

Trailer
Skid Mount
Truck Mount

• Mast-

3"x5" Tubing
Hydraulic Cylinder Raises Mast into Drilling Position
Working Height 16.5'
..... 26.5' (w/ mast extension raised)
Bowl and Slips (Drill Stem Guide / Breakout)

• Hydraulic System-

Hydraulic Reservoir 50 Gal
Hydraulic Pump 14 GPM (HI)
..... 2.5 GPM (LO)
Hydraulic Pressure 2500 PSI

• Engines

18 HP Gasoline
20 HP Diesel-Water Cool
21 HP Diesel-Air
Truck PTO

• Tophead Drive-

Rotation Speed 140 RPM(HI)
..... 25 RPM(LO)
Torque 7900 lb.in.
Fluid Passage 1½"
Mud/Air Rotary Swivel - Side Feed, Direct Drive, Triple Bearing

• Mud Pump-

18 HP 1½"x2"x8.5" Centrifugal

• Pulldown/pullback-

Single Hydraulic Cylinder 3"x68"x2"
Stroke 136"
Chain BL634 Leaf Chain, 17,000lb Ave. Tensile Strength
Pulldown 4900 lbs
Pullback 8835 lbs

• Drill Stem-

Length 10'
Weight 49 lbs
Diameter 2¾" Mid-Body
Tool Joint 2⅝ Mayhew Jr.
Material Tool Joint 4130 Heat Treated
..... Mid-Body-J55

• Trailer-

Tongue Weight 150 lbs
Construction Mig-Welded Heavy Wall Rectangular
Structural Tubing
Ball Hitch 2" w/Hitch Actuated Hydraulic Brake

• Dimensions

Length 13.58'
Width 6.75'
Height 16.5' (drilling position)
..... 6.5' (travel position)
Weight 3500-4000 lbs (depending on options)

• Options

Mast Extension w/Winch	2"x3" Mud Pump w/Diesel
Tool Box	Night Drilling Illumination
Down-The-Hole Hammer	Hydraulic Leveling Jacks
Foam Pump	Hydraulic Cathead

Our continuing effort to improve this equipment may result in specification changes without notification. Current production models may vary slightly in appearance from illustrations and photos.



DeepRock Manufacturing Company

2209 Anderson Road, Opelika, Alabama 36803-0001, U.S.A.
Phone Toll-Free: 1-800-633-8774. Outside U.S.A.: (334) 749-3377
Email: deeprock@deeprock.com Fax: (334) 749-5601