

# Assembling the frame

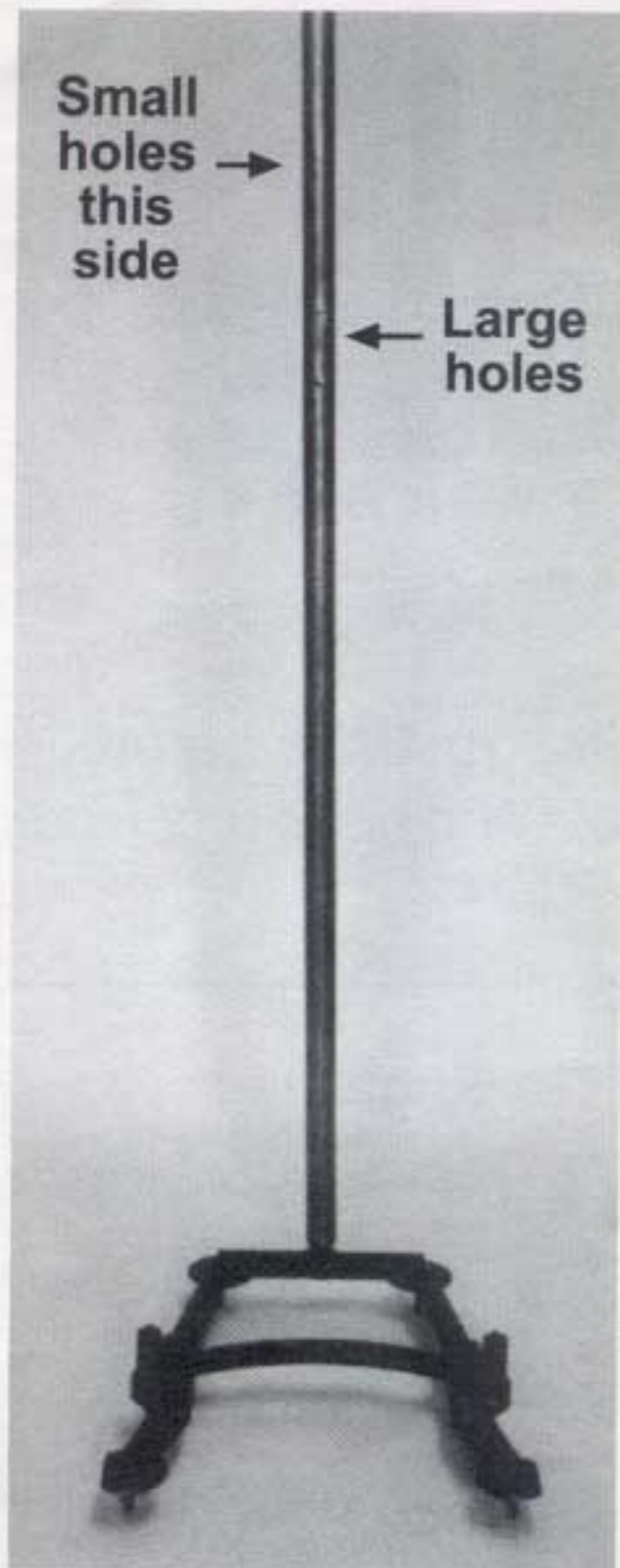

Place the base on a level surface and insert the winch pole onto the rear post. The winch pole has large holes and small holes. The small holes go on top and face the side.

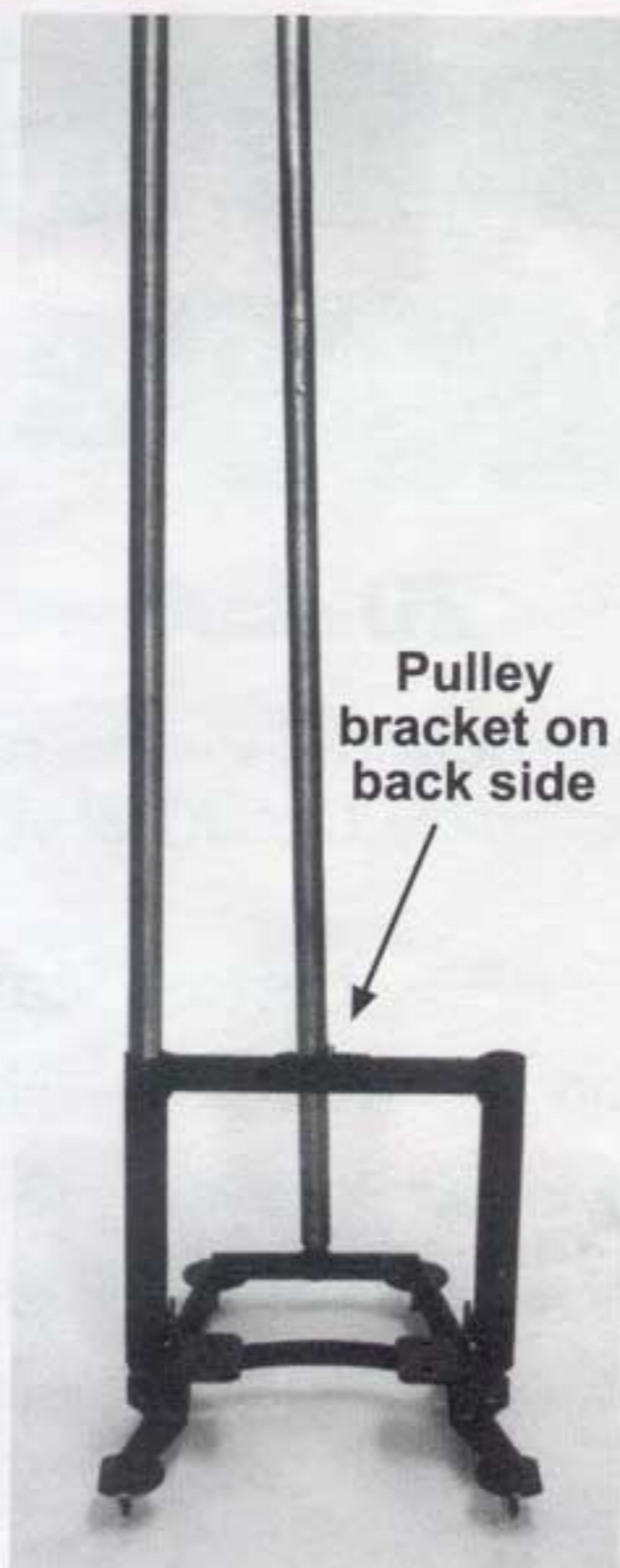

Place the engine cradle onto the front posts of the base. The pulley bracket goes to the rear. Insert the two front poles through the cradle and onto the base posts.



Lay the assembly down with the single winch pole on top. Place the tee top onto the poles.

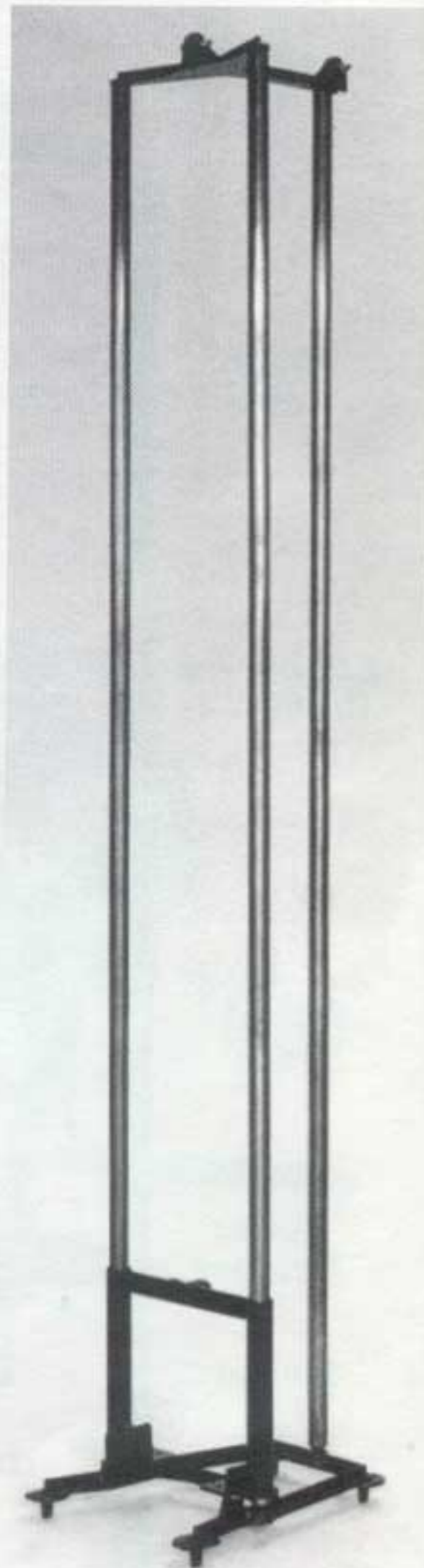

Stand the completed power mast frame upright.

# Attaching the winch & throttle control

Attach the winch with two 1/4 x 2" bolts. Use a small flat washer under the head of the bolts and place two large fender washers between the winch and the pole. Secure with lock nuts. Attach the throttle control on the same side of the pole as the winch handle. The cable should point down.

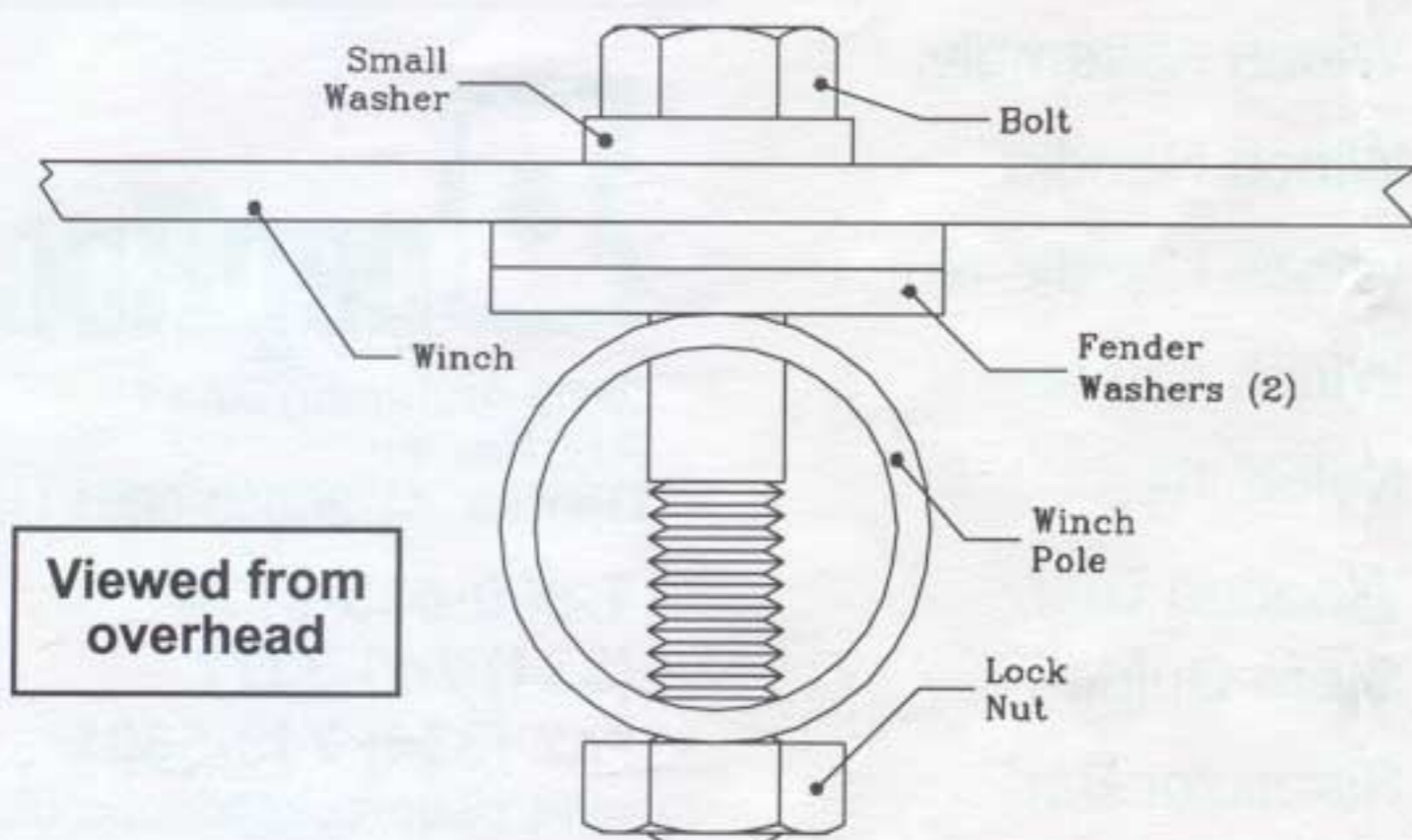

Viewed from overhead

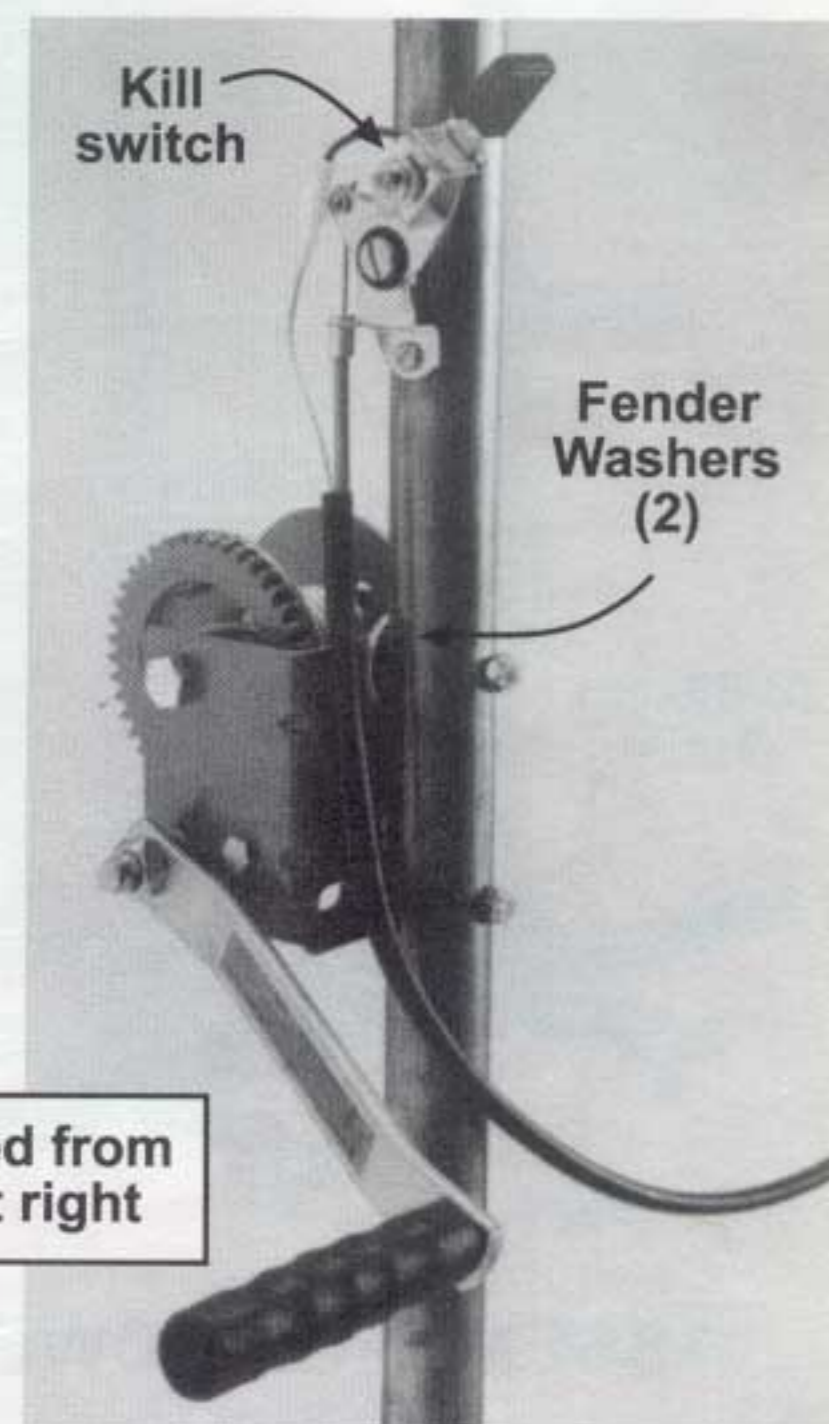

Viewed from front right